

Series CA

MAGNETIC DRIVE CENTRIFUGAL PUMP

EAGLEDRIVE™

For high-flow applications requiring design simplicity, trust the reliable Micropump® Series CA Magnetic Drive Centrifugal Pump. The Series CA's magnetic drive removes the need for direct drive connection to the pump impeller, eliminating leak points associated with shaft seals, while providing energy-efficient fluid delivery. Stainless steel construction provides superior chemical and abrasion resistance. For easy maintenance, the Series CA features an integrated impeller and magnet assembly to reduce the number of rotating parts and maximizing pump life.

PERFORMANCE SUMMARY

MAX HEAD

7.8 Meters (25.6 ft)

MAX FLOW (8000 RPM)

24 L/min (6.3 US gpm)

MAX RATED SYSTEM PRESSURE

13.8 Bar (200 psi)

TEMPERATURE RANGE

-40 to 120°C (-40 to 248°F)

VISCOSITY RANGE

Up to 100 cps

SMALL SIZE

The miniature package size of the Series CA on an EagleDrive™ is easily incorporated into the design of many systems.

SIMPLE CONSTRUCTION

For long life and easy service, Series CA uses a minimal number of moving parts. Its impeller/magnet assembly integrates rotating parts into one element, which reduces alignment problems, failures, and wear rates.

SUPERIOR CHEMICAL & ABRASION RESISTANCE

Impellers and wetted parts are made of PTFE and 316 stainless steel to provide excellent chemical compatibility and abrasion resistance, ensuring maximum service life under the most demanding conditions.

ENERGY EFFICIENT DELIVERY

The Series CA pump housing is investment-cast in 316 stainless steel to ensure smooth flow with maximum corrosion resistance. A volute-type casing passageway is proportioned so fluid maintains its velocity head with minimal energy loss and low required input power.

INNOVATIVE DESIGNS

Micropump uses the latest engineering tools and manufacturing equipment to produce the most innovative pumping solutions available. Products are developed using state-of-the-art CAD, Finite Element Analysis (FEA), and rapid prototyping tools to ensure the highest level of product quality and reliability.

ENHANCED EFFICIENCY

As part of the IDEX Corporation, Micropump offers fully-integrated liquid subassemblies, gas management systems, and precision components. Products include Pumps, Valves, Manifolds, Tubing, Fittings, Degassing/Debubbling Systems, Air Compressors, Vacuum Generators, and HPLC Columns. Additional services are custom fluidic engineering and development, contract manufacturing, extrusion, molding, machining, and diffusion bonding.

WETTED MATERIALS

IMPELLER ASSEMBLY

- ▶ 316 stainless steel impeller
- ▶ PTFE bushings
- ▶ 316 stainless steel/Ferrite driven magnet

PUMP HOUSING

- ▶ 316 stainless steel

STATIC SEALS

- ▶ PTFE

THRUST PLATE

- ▶ PTFE

PUMP CONSTRUCTION

MAGNETIC DRIVE CENTRIFUGAL PUMP

- ▶ Stationary shaft
- ▶ PTFE seal

DRIVE SPECIFICATIONS FOR EAGLEDRIVE™ MSE

SPEED

- ▶ 1000 to 8000 rpm (36V)
- ▶ 500 to 5500 rpm (24V)
- ▶ 250 to 2750 rpm (12V)

SPEED (AT RATED TORQUE)

- ▶ 3750 rpm @ 10 oz-in (24V)

CURRENT AT RATED TORQUE

- ▶ 2A @ 10 oz-in (24V)

POWER SUPPLY

- ▶ 10V to 38V DC

TEMPERATURE RANGE

- ▶ -40 to 120 °C (-40 to 248 °F)

PUMP PERFORMANCE

Power Supply Voltage = 36 VDC

Water @ 1cps

- Speed control = 5V
- Speed control = 1V
- Speed control = 3V
- - - Power Supply Current

CA-S-DEMSE Performance

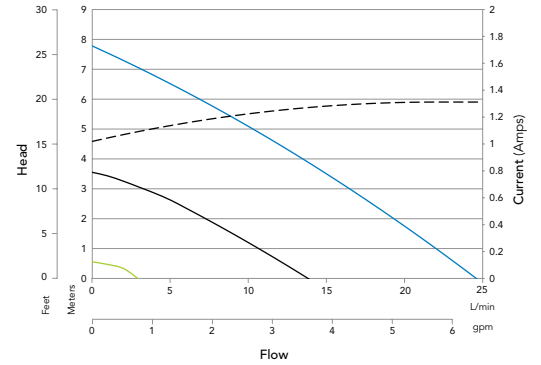

BEST OPERATING POINT: 22L/min (@ 1.4 psi, 5V)

DIMENSIONS

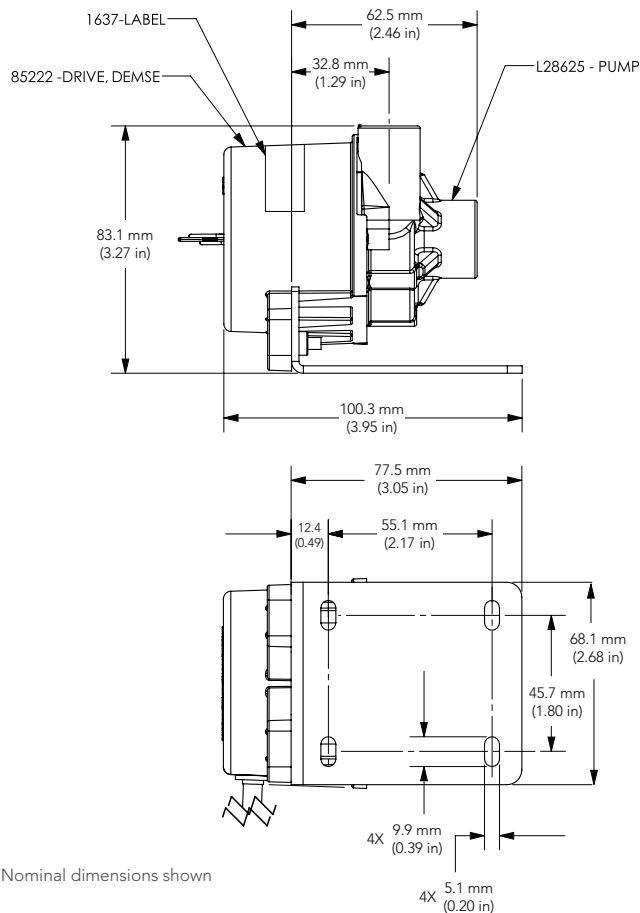

*Units: mm(in). Nominal dimensions shown

MICROPUMP®

Micropump, Inc | A Unit of IDEX Corp. | 1402 NE 136th Avenue • Vancouver, WA 98684

T 800.671.6269 • +1.360.253.2008 | F +1.360.253.8294 | info.micropump@idexcorp.com | www.micropump.com

ACTUAL PERFORMANCE MAY VARY. Specifications are subject to change without notice. ©2016 Micropump, Inc., A Unit of IDEX Corporation. Micropump and the Micropump logo are registered trademarks of Micropump, Inc.

REV. 1/16